

# REVISIONS

| LETTER | DESCRIPTION               | DWG BY | DATE     |
|--------|---------------------------|--------|----------|
| A      | UPDATED DRAWING AND NOTES | SMS    | 10-24-14 |
| B      | REDRAWN AND UPDATED NOTES | JOW3   | 11-18-16 |

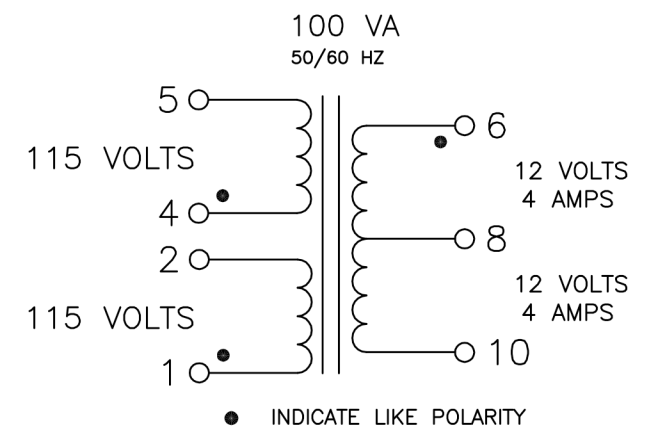
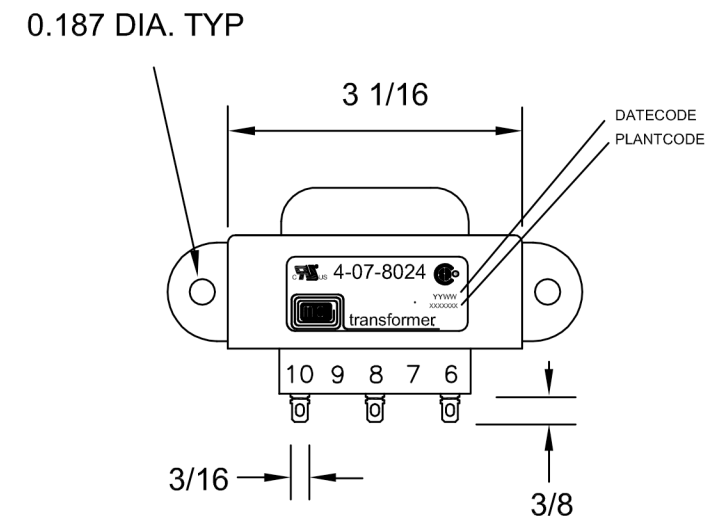
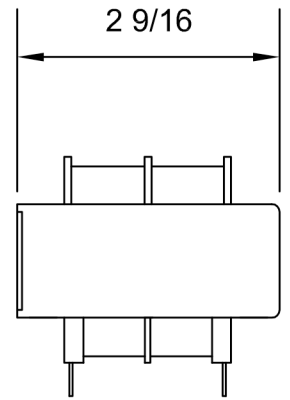
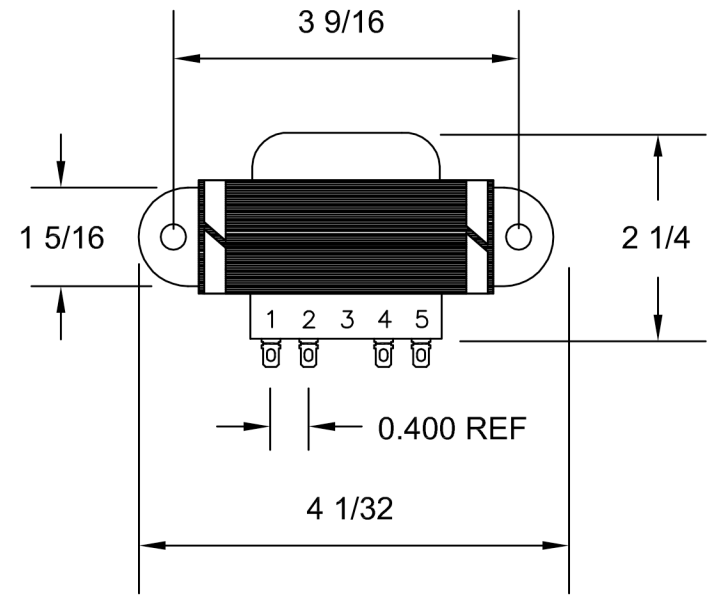

## NOTES:

- 1) UL INSULATION SYSTEM E86543-CLASS F 155°C.
- 2) UL RECOGNIZED COMPONENT: FILE # E86403
- 3) CSA APPROVED COMPONENT: FILE # LR80864
- 4) 2500 VRMS HIPOT BETWEEN PRIMARY AND (SECONDARY + CORE).  
500 VOLTS BETWEEN SECONDARY AND CORE.
- 5) WEIGHT: 2.75 LBS.
- 6) RoHS AND REACH COMPLIANT
- 7) ALL DIMENSIONS ARE IN INCHES.

|            |           |       |         |                |                                 |
|------------|-----------|-------|---------|----------------|---------------------------------|
| <b>MCI</b> |           |       |         |                | <i>NORTH BABYLON N.Y.</i>       |
| CUSTOMER   |           |       |         |                | MCI                             |
| TITLE      |           |       |         |                | QUICK CONNECT POWER TRANSFORMER |
| DRAWN BY   | APPRVD BY | SCALE | DATE    | DRAWING NUMBER |                                 |
| SMS        | JOW       | NONE  | 9-29-95 | 4-07-8024      |                                 |